



Standard Test Methods for Density of Soil and Rock in Place by the Sand Replacement Method in a Test Pit¹

This standard is issued under the fixed designation D4914/D4914M; the number immediately following the designation indicates the year of original adoption or, in the case of revision, the year of last revision. A number in parentheses indicates the year of last reapproval. A superscript epsilon (ϵ) indicates an editorial change since the last revision or reapproval.

1. Scope*

1.1 These test methods cover the determination of the in-place density of soil and rock using a pouring device and calibrated sand to determine the volume of a test pit. The word “rock” in these test methods is used to imply that the material being tested will typically contain particles larger than 3 in. [75 mm].

1.2 These test methods are best suited for test pits with a volume from 0.03 to 0.17 m³ [1 to 6 ft³]. In general, the materials tested would have a maximum particle size of 75 to 125 mm [3 to 5 in.].

1.2.1 For larger sized excavations and soil containing larger particles, Test Method **D5030** is preferred.

1.2.2 Test Method **D1556** or **D2167** are usually used to determine the volume of test holes smaller than 0.03 m³ [1 ft³]. While the equipment illustrated in these test methods is used for volumes less than 0.03 m³ [1 ft³], the test methods allow larger versions of the equipment to be used when necessary.

1.3 Two test methods are provided as follows:

1.3.1 *Test Method A*—In-Place Density of Total Material (Section 10).

1.3.2 *Test Method B*—In-Place Density of Control Fraction (Section 11).

1.4 *Selection of Test Methods:*

1.4.1 Test Method A is used when the in-place density of total material is to be determined. Test Method A can also be used to determine percent compaction or percent relative density when the maximum particle size present in the in-place material being tested does not exceed the maximum particle size allowed in the laboratory compaction test (refer to Test Methods **D698**, **D1557**, **D4253**, **D4254**, and **D7382**). For Test Methods **D698** and **D1557** only, the dry density determined in the laboratory compaction test may be corrected for larger particle sizes in accordance with, and subject to the limitations of Practice **D4718**.

1.4.2 Test Method B is used when percent compaction or percent relative density is to be determined and the in-place material contains particles larger than the maximum particle size allowed in the laboratory compaction test or when Practice **D4718** is not applicable for the laboratory compaction test. Then the material is considered to consist of two fractions, or portions. The material from the in-place dry density test is physically divided into a control fraction and an oversize fraction based on a designated sieve size (see Section 3). The dry density of the control fraction is calculated and compared with the dry density(s) established by the laboratory compaction test(s).

1.5 Any materials that can be excavated with hand tools can be tested provided that the void or pore openings in the mass are small enough (or a liner is used) to prevent the calibrated sand used in the test from entering the natural voids. The material being tested should have sufficient cohesion or particle interlocking to maintain stable sides during excavation of the test pit and through completion of this test. It should also be firm enough not to deform or slough due to the minor pressures exerted in digging the hole and pouring the sand.

1.6 These test methods are generally limited to material in an unsaturated condition and are not recommended for materials that are soft or friable (crumble easily) or in a water condition such that water seeps into the hand-excavated hole. The accuracy of the test methods may be affected for materials that deform easily or that may undergo volume change in the excavated hole from standing or walking near the hole during the test.

1.7 The values stated in either SI units or inch-pound presented in brackets are to be regarded separately as standard. The values stated in each system may not be exact equivalents; therefore each system shall be used independently of the other. Combining values from the two systems may result in non-conformance with the standard.

1.8 All observed and calculated values shall conform to the guidelines for significant digits and rounding established in Practice **D6026**.

1.8.1 The procedures used to specify how data are collected, recorded or calculated in this standard are regarded as the industry standard. In addition they are representative of the

¹ These test methods are under the jurisdiction of ASTM Committee **D18** on Soil and Rock and are the direct responsibility of Subcommittee **D18.08** on Special and Construction Control Tests.

Current edition approved March 1, 2016. Published March 2016. Originally approved in 1989. Last previous edition approved in 2008 as D4914 – 08. DOI: 10.1520/D4914_D4914M-16.

*A Summary of Changes section appears at the end of this standard

significant digits that generally should be retained. The procedures used do not consider material variation, purpose for obtaining the data, special purpose studies, or any considerations for the user's objectives; it is common practice to increase or reduce significant digits of reported data to be commensurate with these considerations. It is beyond the scope of this standard to consider significant digits used in analytical methods for engineering design.

1.9 *This standard does not purport to address all of the safety concerns, if any, associated with its use. It is the responsibility of the user of this standard to establish appropriate safety and health practices and determine the applicability of regulatory limitations prior to use.* For specific hazards statements, see Sections 8 and A1.5.

2. Referenced Documents

2.1 ASTM Standards:²

- [C127 Test Method for Relative Density \(Specific Gravity\) and Absorption of Coarse Aggregate](#)
- [C566 Test Method for Total Evaporable Moisture Content of Aggregate by Drying](#)
- [D653 Terminology Relating to Soil, Rock, and Contained Fluids](#)
- [D698 Test Methods for Laboratory Compaction Characteristics of Soil Using Standard Effort \(12 400 ft-lbf/ft³ \(600 kN-m/m³\)\)](#)
- [D1556 Test Method for Density and Unit Weight of Soil in Place by Sand-Cone Method](#)
- [D1557 Test Methods for Laboratory Compaction Characteristics of Soil Using Modified Effort \(56,000 ft-lbf/ft³ \(2,700 kN-m/m³\)\)](#)
- [D2167 Test Method for Density and Unit Weight of Soil in Place by the Rubber Balloon Method](#)
- [D2216 Test Methods for Laboratory Determination of Water \(Moisture\) Content of Soil and Rock by Mass](#)
- [D3740 Practice for Minimum Requirements for Agencies Engaged in Testing and/or Inspection of Soil and Rock as Used in Engineering Design and Construction](#)
- [D4253 Test Methods for Maximum Index Density and Unit Weight of Soils Using a Vibratory Table](#)
- [D4254 Test Methods for Minimum Index Density and Unit Weight of Soils and Calculation of Relative Density](#)
- [D4718 Practice for Correction of Unit Weight and Water Content for Soils Containing Oversize Particles](#)
- [D4753 Guide for Evaluating, Selecting, and Specifying Balances and Standard Masses for Use in Soil, Rock, and Construction Materials Testing](#)
- [D5030 Test Method for Density of Soil and Rock in Place by the Water Replacement Method in a Test Pit](#)
- [D6026 Practice for Using Significant Digits in Geotechnical Data](#)
- [D7382 Test Methods for Determination of Maximum Dry Unit Weight and Water Content Range for Effective](#)

² For referenced ASTM standards, visit the ASTM website, www.astm.org, or contact ASTM Customer Service at service@astm.org. For *Annual Book of ASTM Standards* volume information, refer to the standard's Document Summary page on the ASTM website.

Compaction of Granular Soils Using a Vibrating Hammer E11 Specification for Woven Wire Test Sieve Cloth and Test Sieves

3. Terminology

3.1 Definitions:

3.1.1 For definitions of terms related to this standard, refer to Terminology [D653](#).

3.2 Definitions of Terms Specific to This Standard:

3.2.1 *control fraction, n*—the portion of a soil sample consisting of particles smaller than a designated sieve size.

3.2.1.1 *Discussion*—This fraction is used to compare in-place density with density obtained from standard laboratory tests. The control sieve size depends on the laboratory test used. Normally, the control fraction is the minus 4.75 mm, or No. 4 [0.187 in.] sieve size material for cohesive or non-free draining materials and the minus 75 mm [3-in.] sieve size material for cohesionless, free-draining materials. While other sizes are used for the control fraction, 9.5 or 19 mm [$\frac{3}{8}$, $\frac{3}{4}$ -in.], these test methods have been prepared using only the No. 4 and the 75 mm [3 in.] sieve sizes for clarity.

3.2.2 *oversize particles, n*—the portion of a soil sample consisting of the particles larger than the designated sieve size for the control fraction selected.

3.2.3 *sand pouring device(s), n*—handheld pouring device(s) that holds the density sand equipped with a long pouring spout for placing the sand with unobstructed flow at a constant drop height.

3.2.3.1 *Discussion*—Multiple cans may be used but they must be of the same design and calibrated.

4. Summary of Test Method

4.1 The ground surface at the test location is prepared and a template (metal frame) is placed and fixed into position. The volume of the space between the top of the template and the ground surface is determined by filling the space with calibrated sand using a pouring device. The mass of the sand required to fill the template in place is determined and the sand removed. Material from within the boundaries of the template is excavated forming a pit. Calibrated sand is then poured into the pit and template; the mass of sand within the pit and the volume of the hole are determined. The wet density of the in-place material is calculated from the mass of material removed and the measured volume of the test pit. The water content is determined and the dry density of the in-place material is calculated.

4.2 The density of a control fraction of the material can be determined by subtracting the mass and volume of any oversize particles from the initial values and recalculating the density.

5. Significance and Use

5.1 These test methods are used to determine the in-place density of compacted materials in construction of earth embankments, road fills, and structure backfill. For construction control, these test methods are often used as the bases for acceptance of material compacted to a specified density or to a percentage of a maximum unit weight determined by a

standard laboratory test method (such as determined from Test Method **D698** or **D1557**), subject to the limitations discussed in **1.4**.

5.2 These test methods can be used to determine the in-place density of natural soil deposits, aggregates, soil mixtures, or other similar material.

NOTE 1—The quality of the result produced by this standard is dependent on the competence of the personnel performing it, and the suitability of the equipment and facilities used. Agencies that meet the criteria of Practice **D3740** are generally considered capable of competent and objective testing. Users of these test methods are cautioned that compliance with Practice **D3740** does not in itself ensure reliable results. Reliable testing depends on many factors; Practice **D3740** provides a means of evaluating some of those factors.

6. Interferences

6.1 Because of possible lower densities created when there is particle interference (see Practice **D4718**), the percent compaction of the control fraction should not be assumed to represent the percent compaction of the total material in the field when using method B with oversize corrections.

6.2 A careful assessment must be made as to whether or not the volume determined is representative of the in-place condition when this test method is used for clean, relatively uniform-sized particles. The disturbance during excavation, due to lack of cohesion, and the void spaces between particles spanned by the liner (if used) may affect the measurement of the volume of the test pit.

NOTE 2—Experience with this test used in cohesionless uniform fine gravels, pea gravels, or processed uniform gravel drain materials have shown errors in test hole volume.

7. Apparatus

7.1 *Balance or Scale*—A balance (or scale) to determine the mass of the calibrated sand and the excavated soil having a minimum capacity of 20 kg [50 lbm] and meeting the requirements of Specification **D4753** for a balance of 1-g [0.002-lbm] readability.

7.2 *Balance or Scale*—A balance (or scale) to determine water content of minus No. 4 material having a minimum capacity of 1000 g [2-lbm] and meeting the requirements of Specification **D4753** for a balance of 0.1 g [0.001 lbm] readability.

7.3 *Drying Oven*—An oven, thermostatically controlled, preferably of the forced-draft type, and capable of maintaining a uniform temperature of $110 \pm 5^\circ\text{C}$ throughout the drying chamber.

7.4 *Sieves*—No. 4, 4.75-mm [0.187-in.] sieve and 75-mm [3-in.] sieve, conforming to the requirements of Specification **E11**.

7.5 *Metal Template*—A square or circular template to serve as a pattern for the excavation. Template dimensions, shapes, and material may vary according to the size of the test pit to be excavated. Refer to **Appendix X1** for recommended template sizes. The template shall be rigid enough not to deflect or bend.

NOTE 3—The template shown in **Fig. 1** represents a design that has been found suitable for this purpose.

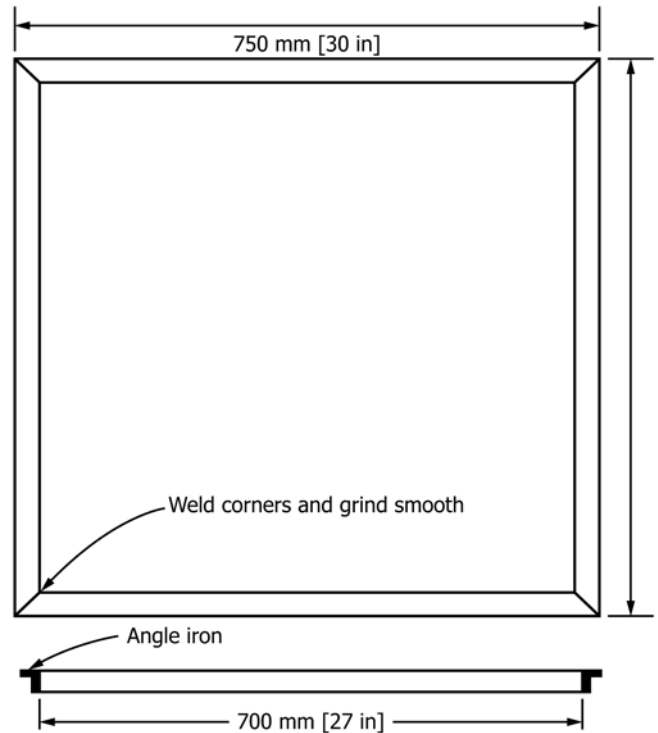

FIG. 1 Typical Metal Template for Excavating Test Pit

7.6 *Liner*, approximately less than 25 μm [1 mil, 0.001 in.] thick and large enough to line the test pit with about 0.3 m [1 ft] extending beyond the outside of the template. Any type of material, plastic sheeting, etc., can be used as long as it is flexible enough to conform to the ground surface.

7.7 *Sand Pouring Devices*—(See **Fig. 2** for some typical devices.) Many types of pouring devices are available. Use multiple 10 to 15-L [3 to 4-gal] containers as long as they meet spout requirements. Larger containers may be used as long as the vertical 50-mm [2-in.] drop height can be maintained. The device must have a spout that will reach into a field test pit so that the drop distance from the end of the spout to the sand surface can be maintained at about 50 mm [2 in.]. The inside diameter of the spout must also be large enough to allow free flow of the sand without clogging.

7.8 *Metal Straightedge*, about 50 mm [2 in.] high, at least 3 mm [$\frac{1}{8}$ in.] thick, and with a length 1.5 times the side length (or diameter) of the metal template, used for screeding excess sand placed in template. It must have a thickness or rigidity such that it will not bend when screeding the sand.

7.9 *Sand*—The sand must be clean, dry, uniform, uncemented, durable, and free flowing. The gradation, physical characteristics, selection, and storage of the sand shall meet the requirements of Test Method **D1556** except that the maximum particle size may be No. 4, 4.75-mm [0.187-in.] sieve.

7.9.1 If the test methods are used for test pits larger than about 0.2 m^3 [6 ft^3], a one-size material relatively free of fines and of a larger particle size, such as pea gravel, may be used.

7.10 *Miscellaneous Equipment*—Shovels for preparing test surface; hammer for seating template; assorted small brushes,